

Notstellantrieb
Emergency actuating
Actionneur de sécurité
Accionamiento de seguridad
Noodaandrijving
Attuatore di emergenza
Drivdon för nöddrift
Nouzový náhon
Napęd awaryjny
Аварийный сервопривод
Kisegítő működtető szerkezet
紧急执行器

de Montagehinweis
en Mounting instructions
fr Instructions de montage
es Indicaciones de montaje
nl Montage-instructie
it Istruzioni di montaggio
sv Montageanvisning
cs Pokyny pro montáž
pl Instrukcja montau
ru Указание по монтажу
hu Szerelési útmutató
zh 安装提示

Kieback&Peter GmbH & Co. KG
Tempelhofer Weg 50, 12347 Berlin/Germany
Telefon +49 30 600 95 - 0, Fax +49 30 600 95 - 164
www.kieback-peter.de, info@kieback-peter.de

Kieback&Peter

MF100-SR-Z

MF100-SR-Z-E

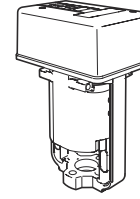

3.10-40.105-99 | 2022-12-09

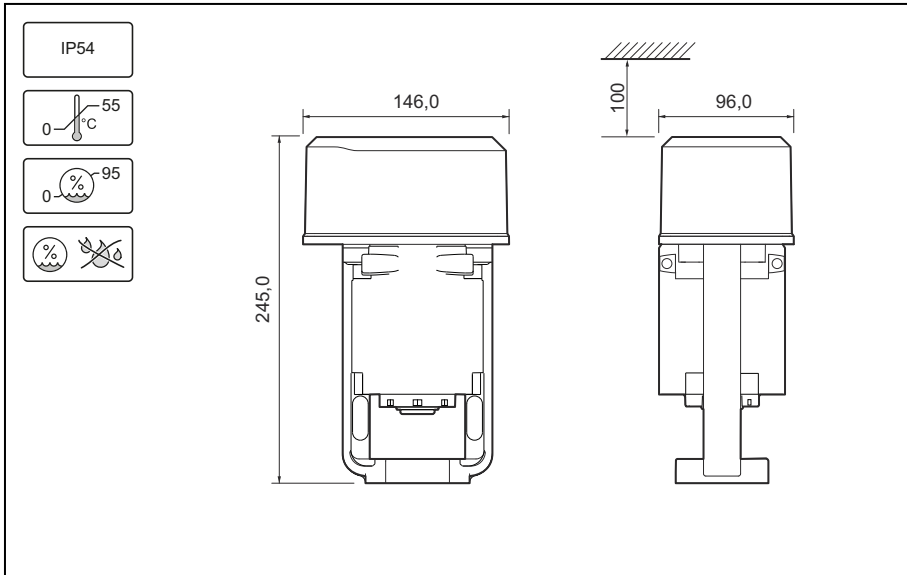

ACHTUNG! Montage und Installation darf nur durch qualifiziertes Fachpersonal vorgenommen werden.

NOTICE! Assembly and installation may only be carried out by qualified specialist personnel.

ATTENTION! Le montage et l'installation doivent uniquement être effectués par du personnel qualifié.

¡ATENCIÓN! El montaje y la instalación sólo lo puede realizar personal técnico calificado.

LET OP! Montage en installatie mogen slechts door geschoold personeel met de nodige kwalificatie worden uitgevoerd.

ATTENZIONE! Fare svolgere i lavori di montaggio e installazione solo da parte di personale qualificato.

WARNING! Montage och installation får endast ske av kvalificerad fackpersonal.

POZOR! Montáž a instalaci smí provádět pouze kvalifikovaný odborný personál.

UWAGA! Montaż i instalację mogą przeprowadzać tylko wykwalifikowani specjaliści.

ВНИМАНИЕ! Монтаж и установка должны производиться только квалифицированным персоналом.

FIGYELEM! A szerelést és telepítést csak szakképzett személyek végezhetik.

注意 安装工作只能由具备相应资质的专业技术人员进行。



GEFAHR! Elektrische Spannung 230V.

DANGER! Electrical voltage 230V.

DANGER! Tension électrique 230V.

¡PELIGRO! Tensión eléctrica 230V.

GEVAAR! Elektrische spanning 230V.

PERICOLO! Tensione elettrica 230V.

FARA! Elektrisk spänning 230V.

NEBEZPEČÍ! Elektrické napětí 230V.

NIEBEZPIECZEŃSTWO! Napięcie elektryczne 230V.

ОПАСНОСТЬ! Электрическое напряжение 230В.

VESZÉLY! Elektromos feszültség 230V.

危險 电压 230V.



ACHTUNG! Quetschgefahr.

NOTICE! Danger of crushing.

ATTENTION! Risque d'écrasement.

¡ATENCIÓN! Peligro de aplastamiento.

LET OP! Beknellingsgevaar.

ATTENZIONE! Pericolo di schiacciamento.

OBSERVERA! Klämningsrisk.

POZOR! Nebezpečí stisku ruky.

UWAGA! Niebezpieczeństwo zgniecenia.

ВНИМАНИЕ! Возможно травмирование рук.

FIGYELEM! Becsípődésveszély.

注意 有压伤危险。

MF100-SR-Z

MF100-SR-Z-E

1

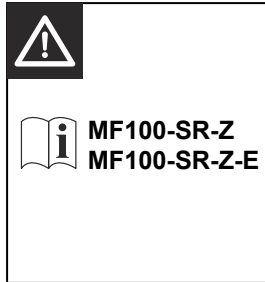
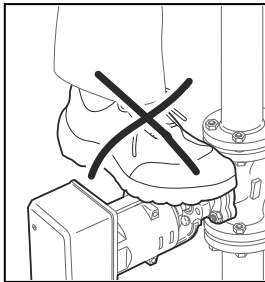
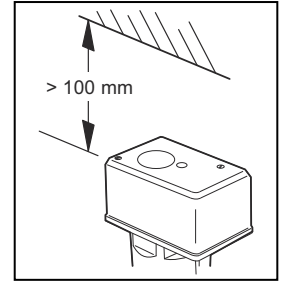
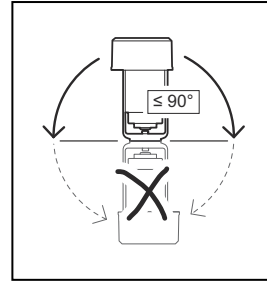
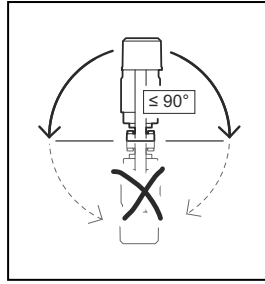
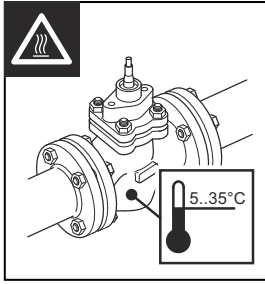
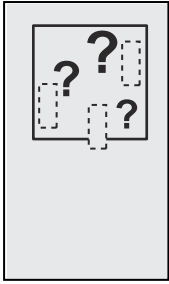

2

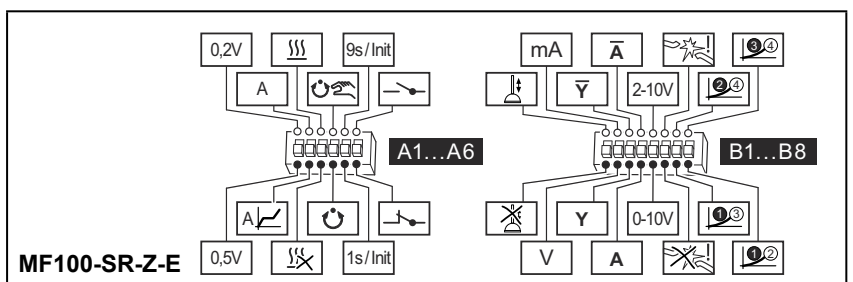
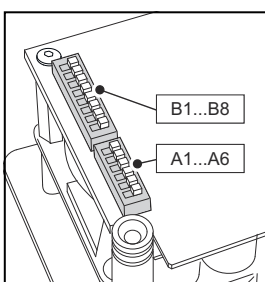
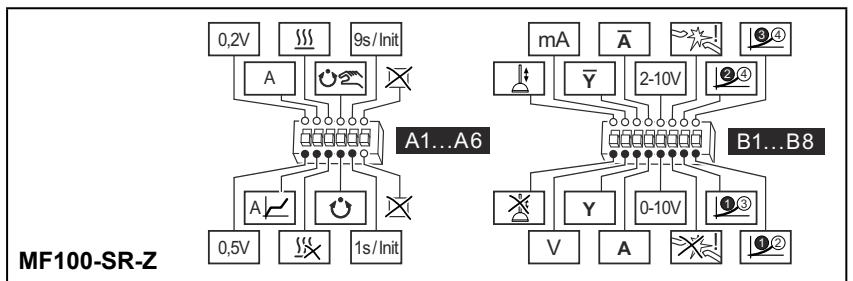
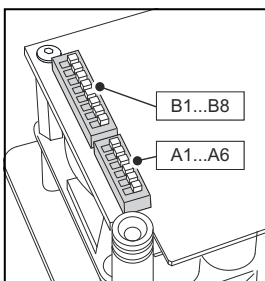
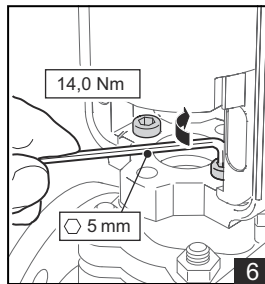
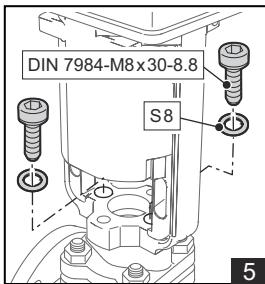
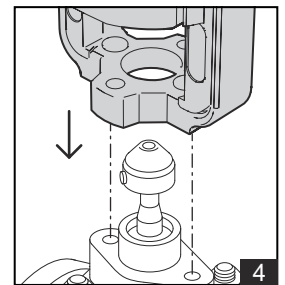
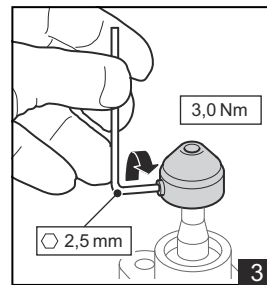
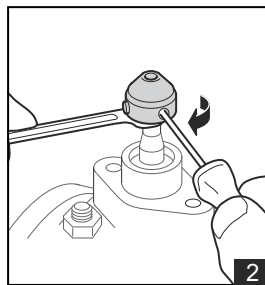
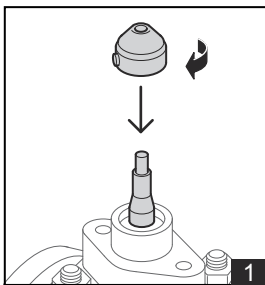
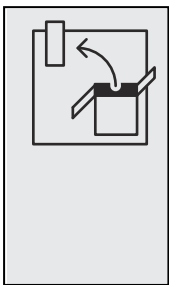

MF100-SR-Z
MF100-SR-Z-E

3

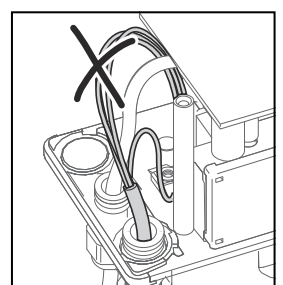
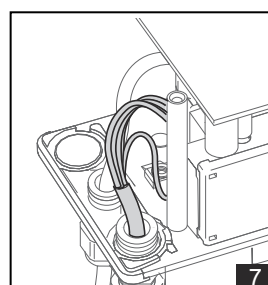
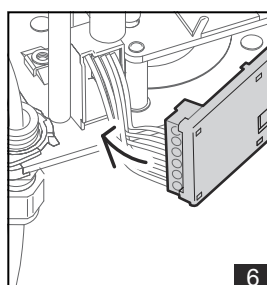
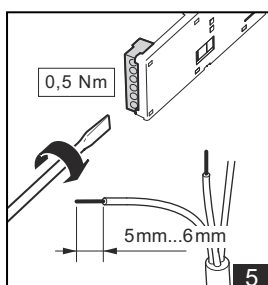
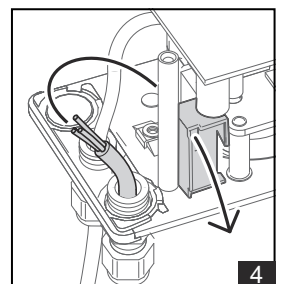
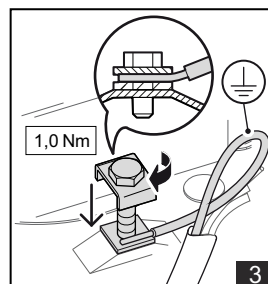
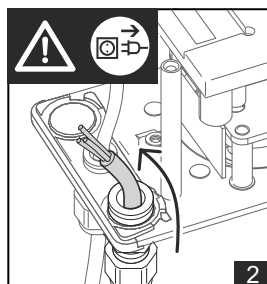
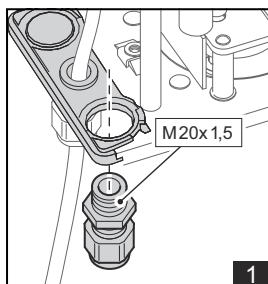
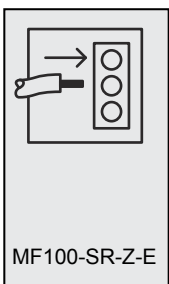
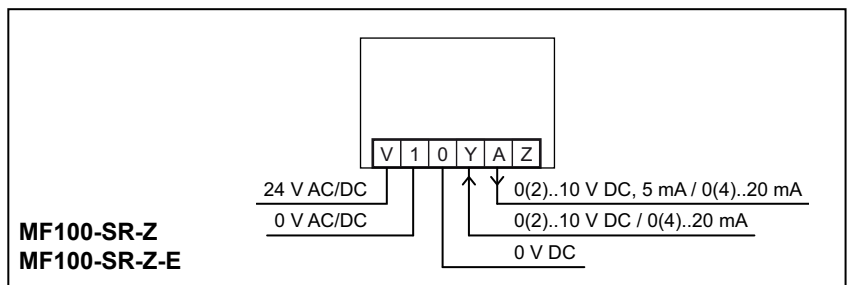
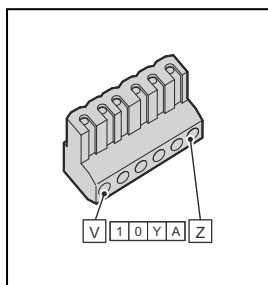
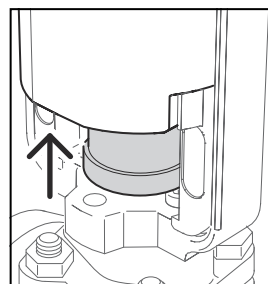
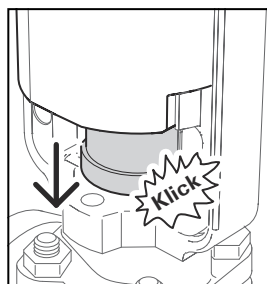
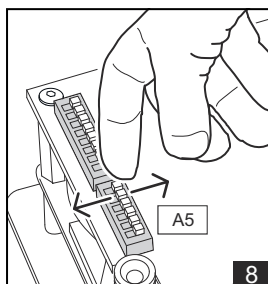
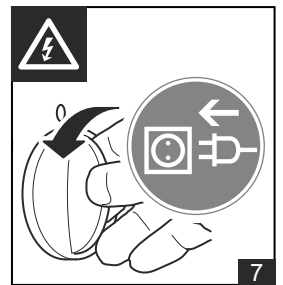
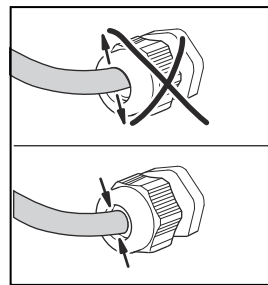
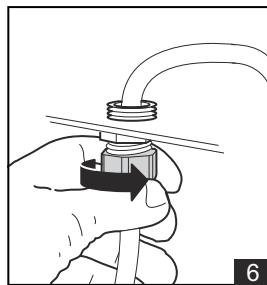
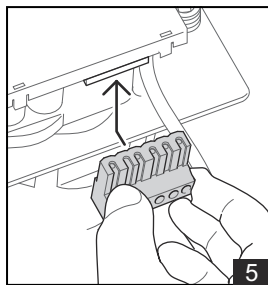
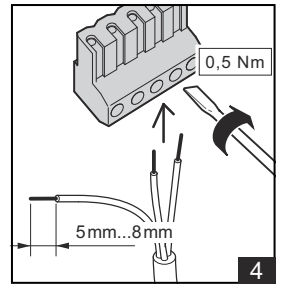
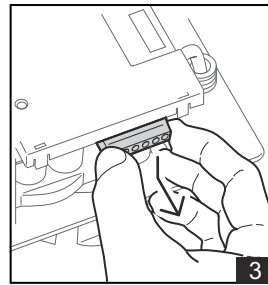
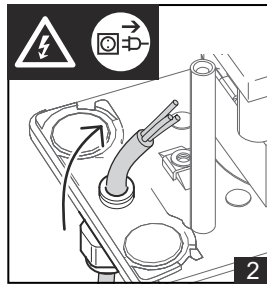
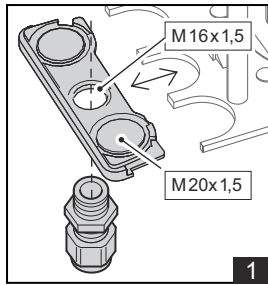
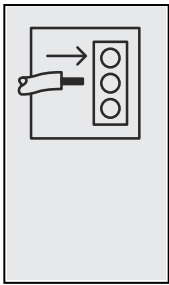

4

